

ALTIRA PARK, HERNE BAY

Archaeological Desk-Based Assessment In advance of Development at the Altira Park, Blacksole Farm, Herne Bay, Kent

Prepared by SWAT Archaeology

As part of

Planning Application for a Foodstore, Business Units and Petrol Filling Station
For Terrace Hill (Herne Bay) Limited

DATE: NOVEMBER 2012 (Updated March 2013)



Contents

<i>List of Figures</i>	<i>iii</i>
<i>List of Plates</i>	<i>iii</i>
1. SUMMARY.....	4
2. INTRODUCTION.....	7
2.1 Planning Background	7
2.2 The Proposed Development	8
2.3 Projects Constraints	8
2.4 Geology and Topography.....	8
3. AIMS AND OBJECTIVES.....	9
3.1 Introduction	9
3.2 Desktop Study – Institute For Archaeologists (revised 2011)	9
4. METHODOLOGY	10
4.1 Desk-Based Assessment.....	10
4.1.1 Archaeological databases	10
4.1.2 Historical documents	10
4.1.3 Cartographic and pictorial documents	11
4.1.4 Aerial photographs	11
4.1.5 Geotechnical information	11
4.1.6 Secondary and statutory resources	11
5. ARCHAEOLOGICAL AND HISTORICAL DEVELOPMENT	11
5.1 Introduction	12
5.2 Archaeological investigations carried out within the surrounding area	12
5.3 Archaeological investigations carried out to date within the PDA.....	14
5.4 Scheduled Monuments, listed buildings, Historic parks & Gardens and Conservation Areas.....	15
5.5 Palaeolithic, Mesolithic, Neolithic and Bronze Age.....	15
5.6 Iron Age.....	16
5.7 Romano-British	16
5.8 Anglo-Saxon	16
5.9 Medieval	17
5.10 Post-Medieval	17
5.11 Modern	17
5.12 Undated	17

5.13	Cartographic Sources and Map Regression	17
5.14	Aerial Photographs	17
6.	ARCHAEOLOGICAL POTENTIAL	17
6.1	Palaeolithic, Mesolithic, Neolithic and Bronze Age	17
6.2	Iron Age.....	18
6.3	Romano-British.....	18
6.4	Anglo-Saxon	18
6.5	Medieval	18
6.6	Post-Medieval	18
7.	IMPACT ASSESSMENT	18
7.1	Existing Impacts	18
7.2	Proposed Impacts	19
8.	MITIGATION	19
9.	OTHER CONSIDERATIONS	20
9.1	Archive	20
9.2	Reliability/limitations of sources	21
9.3	Copyright.....	21
10.	ACKNOWLEDGEMENTS	21
11.	REFERENCES & BIBLIOGRAPHY	21

List of Plates

- Plate 1. Part of the Development Site (facing east)
- Plate 2. Site of proposed filling station

List of Figures

- Fig.1 Blacksole Farm archaeology
- Fig.2 Blacksole Farm showing boundary of proposed development and aerial view
- Fig.3 Blacksole Farm showing boundary of proposed development and earlier evaluation trenching
- Fig. 4 Food store access road/car park construction details
- Fig. 5 Carriageway and footway construction details
- Fig. 6 Food store service yard typical construction details

Archaeological Desk-Based Assessment in Advance of Development at the Altira Park, Blacksole Farm, Herne Bay, Kent

NGR: 619606 167254

1 SUMMARY

SWAT Archaeology (Swale & Thames Survey Company) has been commissioned to carry out an archaeological desk-based assessment of the proposed development at the Altira Park as part of the current Planning Application for a food store, business units and a petrol filling station.

This Desk Based Assessment examines the wide variety of archaeological data held by Canterbury City Council, Kent County Council and other sources. This data is reviewed and it is noted that an archaeological evaluation has been carried out on the location of the main part of the development, i.e. the proposed food store site, business units and car park. Archaeology was revealed in some areas from the evaluation but as the depth of the exposed archaeology was about 0.50m below ground level it is recommended a programme of 'Strip, Map and Sample' should be implemented for only some areas of development. However, the access roads, car parking areas and loading bays are to be built up on the natural geology which will enable preservation in situ of any archaeology (Figs 4-6). If piling is the preferred method of build for the food store English Heritage guidelines recommend that in an area of insignificant archaeology piling can be the preferred method of 'preservation in situ' (Piling and Archaeology. An English Heritage Guidance Note 2007). The location of the petrol filling station has been recognised to be in an area of recent major earthmoving in connection with the adjacent motorway, bridge incline and the bridge itself. Here it is recommended an Archaeological Watching Brief would be the preferred method of mitigation. However, the Archaeological Officer, Canterbury City Council, has written that 'evaluation by trial trenching and/or geophysical survey may be required across the site of the proposed petrol station' (R. Cross 07/01/13). Both recommendations, when agreed, are to be undertaken to a written scheme of investigation (WSI) approved by the Archaeological Officer, Canterbury City Council.

The proposed development at the Altira Park is managed by Terrace Hill (Herne Bay) Ltd, 1 Portland Place, London W1B 1PN

The site is located to the north of the Thanet Way (centred on National Grid Reference 619606 167254), adjacent to Bogshole Lane to the east (see Fig. 1). The site is c.2.6ha in extent, relatively flat with a slight decline to the south (Plate 1) at a height of about 35-37mAOD (above Ordnance Datum).

1.1 History of the site

In the area of the site now subject to a planning application for business units and a food store Swale & Thames Survey Company (SWAT) carried out an archaeological evaluation between May 2007 and February 2008 (Fig. 3 & Appendix 1).

The work was carried out in accordance with the requirements set out within an Archaeological Specification (SWAT 25th January 2007) and in discussion with Richard Cross, the Archaeological Officer, Canterbury County Council. 111 evaluation trenches revealed the presence of enclosures, drove ways, pits and post holes representative of extensive settlement dated to the prehistoric periods.

Archaeological horizons were shown to survive at a depth approximately 0.5m below the existing ground level. Truncation of archaeological horizons was relatively minimal, evident only by the existence of low impact field drains.

Previous work in the western area of Altira Park has comprised Phase I (Archaeological Evaluation, April 2007) and subsequent Phase II mitigation (Archaeological Strip, Map and Sample excavation).

The evaluation report of 2008 details two further phases (11 & 1V) of archaeological evaluation on parts of the proposed development site.

Table 1 below summarises phases of archaeological work so far undertaken at Altira Park:

Phase	Description
I	Archaeological Evaluation of the western area of the proposed development area, as detailed by SWAT with an Archaeological Evaluation Report (Allen 2007)
II	Archaeological mitigation in response to Phase I in the form of a Strip, Map and Sample excavation as detailed by SWAT within an archaeological specification (Britchfield 2007).
III	Archaeological Evaluation carried out in April 2007 on the eastern extent of the proposed development area (Appendix 1)
IV	Archaeological Evaluation carried out in February 2008 on the eastern extent of the proposed development area (Appendix 1)
V	Archaeological mitigation in response to Phases III and IV as required by Canterbury City Council

Table 1. Phases of Archaeological Fieldwork at Altira Park

The Archaeological Evaluation of April 2007 indicated the presence of extensive, multi-phase remains associated with Prehistoric and Roman-period occupation/settlement activity, in addition to Prehistoric industrial activity and probable pottery production. The results of the evaluation appeared to confirm that the area was relatively well populated during the Late Bronze/Early Iron Age but, in common with a minority of other sites in the area, the site also produced evidence of earlier occupation. Subsequent excavation (Phase 2) within the western extent of the site has confirmed the presence of multi-phased occupation dating from the Neolithic and Bronze Age through the post-Medieval period when the farm was established. Early results suggested a nucleated Prehistoric settlement, with associated domestic, agricultural and possible industrial land use, set out within a managed agricultural landscape. Excavations at Blacksole Farm have thus afforded an exciting and rare opportunity to study the landscape on both a macro - and micro scale level.

To date, three roundhouses have been uncovered (two of which have been dated to the Middle Bronze Age with the third associated with the Iron Age) providing the focal point for a multi-phase settlement comprising pits and ditches associated with the division of the landscape for arable, pastoral and domestic purposes. Further rectangular enclosures, along with associated drove ways, field boundaries and smaller internal divisions, reveal a network of herding features essential to the successful management and control of livestock associated with the farmsteads.

Interrupted parallel ditches or drove ways set out at right-angles, are coupled with enclosure ditches and features that can be attributed to elements of animal husbandry. Such features would typically comprise collections of corrals or pens, funnels and herding 'race', used for droving, batching and sorting of livestock. Evidence for drafting gates, such as the 'three way drafting gate system' as suggested by Francis Pryor (1998) also appeared to be represented on site. A possible longhouse was revealed, comprising a series of substantial post holes that contained Neolithic waste flakes distributed in a circular pattern (around a post?) as well as a much earlier tranchet axe of Mesolithic date, possibly kept and ceremoniously discarded?

While it is currently believed that the primary focus of the site would have been associated with agrarian field management and control of domesticated livestock

(within a co-axial system of land division), issues of social identity and complexity would have no doubt been visible within the contemporary landscape. Domestic structures are clearly present and yet sadly, to date, funerary and even monumental semblances (all of which are indicative of the Middle Bronze Age) are surprisingly absent.

Evaluation trenches to the east have revealed the presence of enclosures, drove ways, pits and post holes representative of extensive contemporary settlement, thus confirming the continuation of the landscape over the entirety of the site.

2 INTRODUCTION

2.1 Planning Background

National Planning Policy Framework (2012)

It is worth quoting from this long awaited planning document, in particular Section 12, pages 30-34.

12. Conserving and enhancing the historic environment

126. Local planning authorities should set out in their Local Plan a positive strategy for the conservation and enjoyment of the historic environment, including heritage assets most at risk through neglect, decay or other threats. In doing so, they should recognise that heritage assets are an irreplaceable resource and conserve them in a manner appropriate to their significance. In developing this strategy, local planning authorities should take into account:

- the desirability of sustaining and enhancing the significance of heritage assets and putting them to viable uses consistent with their conservation;
- the wider social, cultural, economic and environmental benefits that conservation of the historic environment can bring;
- the desirability of new development making a positive contribution to local character and distinctiveness; and
- opportunities to draw on the contribution made by the historic environment to the character of a place (para.126).

128. In determining applications, local planning authorities should require an applicant to describe the significance of any heritage assets affected, including any contribution made by their setting. The level of detail should be proportionate to the assets' importance and no more than is sufficient to understand the potential impact of the proposal on their significance. As a minimum the relevant historic environment record should have been consulted and the heritage assets assessed

using appropriate expertise where necessary. Where a site on which development is proposed includes or has the potential to include heritage assets with archaeological interest, local planning authorities should require developers to submit an appropriate desk-based assessment and, where necessary, a field evaluation.

129. Local planning authorities should identify and assess the particular significance of any heritage asset that may be affected by a proposal (including by development affecting the setting of a heritage asset) taking account of the available evidence and any necessary expertise. They should take this assessment into account when considering the impact of a proposal on a heritage asset, to avoid or minimise conflict between the heritage asset's conservation and any aspect of the proposal.

130. Where there is evidence of deliberate neglect of or damage to a heritage asset the deteriorated state of the heritage asset should not be taken into account in any decision.

NPPF paragraphs 131; 134; 135; 139; 140 and 141 are also relevant to consider.

The principles and policies set out in this section apply to the heritage-related consent regimes for which local planning authorities are responsible under the Planning (Listed Buildings and Conservation Areas) Act 1990, as well as to plan-making and decision-taking.

This Desk-Based Assessment therefore forms the initial stage of the archaeological investigation and is intended to inform and assist in decisions regarding archaeological mitigation for the proposed development and associated planning applications.

2.2 The Proposed Development

The proposed development will comprise three blocks of business units, a food store with associated car parking and a petrol filling station.

2.3 Project Constraints

No project constraints were encountered during the data collection for this assessment.

2.4 Geology and Topography

The Geological Survey of Great Britain (1:50,000) shows that the geology of the site and its surrounds consists of Tertiary London Clay overlain by Pleistocene gravels, which are in turn overlain by Brickearth. The Brickearth also frequently contains

gravel spreads (Holmes 1981, 49, 72 and 73) and is therefore probably also Pleistocene in origin for the most part.

3 AIMS AND OBJECTIVES

3.1 Introduction

The Desk-Based Assessment was commissioned by Terrace Hill (Herne Bay) Ltd in order to support a planning application for the development of the site at Altira Park. Canterbury City Council planners have requested an Archaeological Desk-based Assessment Report to clarify the extent of known archaeology on the development site.

3.2 Desktop Study – Institute for Archaeologists (revised 2011)

This desktop study has been produced in line with archaeological standards, as defined by the Institute for Archaeologists (revised 2011). A desktop, or desk-based assessment, is defined as being:

“A programme of study of the historic environment within a specified area or site on land, the inter-tidal zone or underwater that addresses agreed research and/or conservation objectives. It consists of an analysis of existing written, graphic, photographic and electronic information in order to identify the likely heritage assets, their interests and significance and the character of the study area, including appropriate consideration of the settings of heritage assets and, in England, the nature, extent and quality of the known or potential archaeological, historic, architectural and artistic interest. Significance is to be judged in a local, regional, national or international context as appropriate”. (2011)

The purpose of a desk-based assessment is to gain an understanding of the historic environment resource in order to formulate as required:

- 1. an assessment of the potential for heritage assets to survive within the area of study*
- 2. an assessment of the significance of the known or predicted heritage assets considering, in England, their archaeological, historic, architectural and artistic interests*

3. strategies for further evaluation whether or not intrusive, where the nature, extent or significance of the resource is not sufficiently well defined

4. an assessment of the impact of proposed development or other land use changes on the significance of the heritage assets and their settings

5. strategies to conserve the significance of heritage assets, and their settings

6. design strategies to ensure new development makes a positive contribution to the character and local distinctiveness of the historic environment and local place-shaping

7. proposals for further archaeological investigation within a programme of research, whether undertaken in response to a threat or not.

IFA (2011)

4 METHODOLOGY

4.1 Desk-Based Assessment

4.1.1 Archaeological databases

The local Historic Environment Record (HER) held at Canterbury City Council and Kent County Council provides an accurate insight into catalogued sites and finds within both the proposed development area and the surrounding environs of Blacksole Farm.

The Archaeology Data Service Online Catalogue (ADS) and was also used. The search was carried out within a 750m radius of the proposed development site (20/10/12). The Portable Antiquities Scheme Database (PAS) was also used as an additional source as the information contained within is not always transferred to the local HER.

4.1.2 Historical documents

Historical documents, such as charters, registers, wills and deeds etc were not relevant to this specific study as the study is concerned primarily with landscape and its archaeology.

4.1.3 Cartographic and pictorial documents

A full map regression exercise was undertaken during this assessment. Research was carried out using resources offered by Kent County Council, the Internet and Ordnance Survey Historical mapping.

4.1.4 Aerial photographs

The study of aerial photograph's were studied but are not applicable to this study as the immediate area around the development site has been subject to intensive archaeological excavation and recording whilst the main area of proposed development has been subject to an archaeological evaluation.

4.1.5 Geotechnical information

An archaeological evaluation was carried out in April 2007 on the main area proposed for development, but not in the area of the proposed filling station (Appendix 1).

4.1.6 Secondary and statutory resources

Secondary and statutory sources, such as regional and periodic archaeological studies, landscape studies; dissertations, research frameworks and websites are considered appropriate to this type of study and have been included within this assessment where necessary.

5 ARCHAEOLOGICAL AND HISTORICAL DEVELOPMENT

Prehistoric	Palaeolithic	c. 500,000 BC – c.10,000 BC
	Mesolithic	c.10,000 BC – c. 4,300 BC
	Neolithic	c. 4.300 BC – c. 2,300 BC
	Bronze Age	c. 2,300 BC – c. 600 BC
	Iron Age	c. 600 BC – c. AD 43
Romano-British		AD 43 – c. AD 410
Anglo-Saxon		AD 410 – AD 1066
Medieval		AD 1066 – AD 1485
Post-medieval		AD 1485 – AD 1900
Modern		AD 1901 – present day

Table 1 Classification of Archaeological Periods

5.1 Introduction

The Archaeological record within the area around Blacksole Farm is diverse and comprises possible activity dating from one of the earliest human period in Britain (the Neolithic) through to the post-medieval period. Blacksole Farm is situated to the west of the main Roman road running from Canterbury to Reculver. The geographic and topographic location of Blacksole Farm is within a landscape that has been the focus of trade, travel and communication since the Neolithic.

This section of the assessment will focus on the archaeological and historical development of this area, placing it within a local context. Each period classification will provide a brief introduction to the wider landscape, followed by a full record of archaeological sites, monuments and records within the site's immediate vicinity. Time scales for archaeological periods represented in the report are listed on the previous page in **Table 1**.

5.2 Archaeological investigations carried out within the surrounding area

An extensive archaeological narrative for the surrounding area is provided within the archaeological evaluation report prepared by SWAT (Allen 2007) for the adjacent site and need not be repeated in this document. That said, three sites are of particular relevance due to their proximity to Blacksole Farm. Therefore, for the sake of consistency, extracts from the report prepared by SWAT (2007) are detailed below; **Bogshole Lane A, Beltinge (NGR TR 1975 6720)** - During archaeological monitoring of trenching in advance of pipe laying, part of a Mid Iron Age settlement site was discovered on either side of Bogshole Lane, near Beltinge, some 500m east of the present site (Parfitt and Hutchinson 1995, 5). Here, gullies, ditches, post-holes, pit complexes, a four-poster structure (possibly the remains of a raised grain store) and part of the remains of a round house were exposed and over 2000 potsherds recovered, most being dated to c. 500 - c. 300 BC. The remains of the Iron Age round house were particularly well preserved, consisting of a penannular gully (presumably an eaves gully) with an internal diameter of 14m, and containing a cluster of post-holes and post-pits.

Bogshole Lane B, Beltinge (NGR TR 2045 6770) - This site lies on a gentle, east-facing slope between May Street and Bogshole Lane, some 50m east of the Bogshole Lane A site and some 500m east of the present site. The Bogshole Lane A and B remains may, in part, supply evidence for the same phase of occupation activity. If so, an extensive area for this activity is indicated. On the Bogshole Lane B site eleven pits, a gully, a post hole and parts of four ditches were exposed, one of which produced

about 50 sherds of Neolithic pottery (Parfitt and Hutchinson 1995). Other than the ditches, the features were, on the basis of limited ceramic evidence, of probable Late Bronze/Early Iron Age date. However, the north-east/south-west and north-west/south-east alignment of the ditches suggested that they may have represented an eastern extension of the ditched Late Iron Age/Early Roman- period field system exposed on the Bogshole Lane A site. If so, the small amount of Late Bronze/Early Iron Age pottery in the Bogshole Lane B ditches was residual.

Bogshole Lane C, Broomfield (NGR TR 1985 6695) – Here, copious evidence of prehistoric activity was uncovered in the form of pits, field/boundary ditches and an expansive north-east/south-west aligned metalled trackway, the latter dated on the basis of an overlying bronze hoard to earlier than c. 850 - c. 700 BC . Occupation activity predating and including the Mid to Late Bronze Age is indicated (Allen 2001, 12; Helm undated, Helm 2003, 23).

Perhaps of more interest, in archaeological terms, was the presence of a very large, roughly circular pit (average diameter 14.5m). It was excavated to a depth of 2.3m, at which point excavation was abandoned in the interests of safety, but the pit was clearly of considerably greater depth. It had been subject to at least two major re-cuts during prehistory, presumably because its location within London Clay-dominated terrain meant that it was subject to continual infilling through collapse and colluvial down-flow. In addition, several large pits of unknown function had been cut at intervals into the fills of the feature, as had a large number of roughly circular pits. These surrounded the large circular pit and, in a small number of cases, were cut (again at intervals) into its internal fills. A distinctive common feature of the smaller pits, which had depths of between 0.12 - 0.3m and diameters of between 0.3 - 1.47m, was their fills, which in all cases consisted of compacted burnt daub and charcoal. The features as a whole provide good circumstantial evidence for ritual activity, as it is difficult to account for the size, form and complexity of the overall structure otherwise. If the original structure did indeed have a ritual function, it represents a rare example of a prehistoric ritual monument in the London-Clay dominated parts of north Kent. A Late Bronze Age hoard was discovered in a small pit 40m south of the probable ritual monument (Allen 2001, 12). The hoard, which consisted of 27 copper alloy (bronze) fragments, was retrieved from a pit which also contained five flint-tempered potsherds of Late Bronze/Early Iron type Age representing the remains of at least three vessels. This suggested that the hoard was buried in or near a settlement, probably the Willow Farm settlement some 400m to the north-west, in what was an already deforested area. A more precise date than

that derivable from the potsherds was indicated by the bronze hoard, which was of Ewart Park type, dated to the last part of the Bronze Age (c. 850 - c. 700 BC). Settlement and/or ritual activity on the Bogshole Lane site at Broomfield appears to have ceased some time during the Early Iron Age, probably in the sixth century BC and, as in the case of the nearby Willow Farm site, occupation activity appears not to have resumed until the Late Iron Age, when a drainage ditch containing grog-tempered 'Belgic' pottery was cut across the site. However, the presence across the site of a low-intensity scatter of ceramic material of the same type pointed to small-scale Late Iron Age settlement activity, and a single rectangular posted structure dated by its associated ceramics to the Early-Mid Roman period suggested that settlement activity continued up to the mid third century AD or thereabouts, as was also the case for the nearby Willow Farm site.

Intermittent archaeological work over a 10 year period, in advance of the development of Thanet Way, Wraik Hill and Clapham Hill at Seasalter, c.2km southwest of the site, revealed extensive remains of a late Bronze Age to late Iron Age settlement, comprising rubbish pits, post-holes, hearths, ditches, ovens, a trackway and abundant ceramic evidence. Initial work on the route of the Thanet Way was initially a field-walking programme which revealed that the land on the line of the proposed route was covered by a thin but continuous scatter of artefacts in the form of medieval and post-medieval tile and pottery, some prehistoric struck flints and more commonly, burnt flints. Some Roman material was also recovered towards the eastern end of the route and in the vicinity of the proposed development (Allen, T. & Parfitt, K. 1990: 3-4).

5.3 Archaeological investigations carried out to date, within the Proposed Development Area (PDA) The archaeological evaluation carried out by SWAT Archaeology in April 2007 (Phase I) indicated the presence of extensive, multiphase remains associated with prehistoric and Roman-period occupation/settlement activity in addition to large-scale prehistoric industrial activity and probably pottery production. The results of the evaluation appeared to confirm that the Levels were relatively well populated during the Late Bronze/Early Iron Age but, in common with a minority of the other sites in the area, the site also produced evidence of earlier occupation activity. Evidence for significant activity during the Mid Iron Age was lacking but renewed activity during the Late Iron Age and probably into the Early Roman period was indicated, again reflecting a general theme. Allen (2007:30) suggests that evidence pointed to the remains of a possibly high-status Mid Roman-

period settlement being present in the northern part of the Phase I evaluation area. Archaeological excavations within the western extent of the PDA (Phase II) has confirmed the presence of multi-phased occupation dating from the Bronze Age through the post-medieval period. Results suggest nucleated prehistoric settlement, including individual roundhouses with associated domestic, agricultural and possibly industrial land use, set out within a managed agricultural landscape. Roman and medieval remains appear to have been focused along the northern extent of the western PDA, as suggested by Allen (2007: 30).

5.4 Scheduled Monuments, Listed Buildings Historic Parks & Gardens and Conservation Areas

No scheduled monuments are recorded within the confines of the proposed development site. However, two buildings in the near vicinity are identified. 100m west of the proposed development site (Kent HER: TR 16 NE 1094) a locally listed building (7166) of Early to Mid 19th century two storey weather boarded building is close to a c.17th century barn, part of Blacksole Farm, and again locally listed (7167).

5.5 Prehistoric (Palaeolithic, Mesolithic, Neolithic and Bronze Age)

The Palaeolithic represents the earliest phases of human activity in the British Isles, up to the end of the last Ice Age. Palaeolithic dated material occurs in north and east Kent, especially along the Medway and Stour Valleys. The Palaeolithic presence within the assessment area has been identified from a number of find spots. In particular at Bishopstone Glen 1km to the north of the development site (Kent HER: TR 26 NW 20).

The Mesolithic period reflects a society of hunter-gatherers active after the last Ice Age. The Kent HER has no record of archaeological evidence from this period within the assessment area. However, evidence of Mesolithic activity in the form of flint tools and flakes has been retrieved in the archaeological investigations at Altira Park.

The Neolithic period, the beginning of a sedentary lifestyle based on agriculture and animal husbandry is represented within the assessment area by a potential Neolithic building found in the recent archaeological investigations at Altira Business Park.

The Bronze Age, a period of large migrations from the continent and more complex social developments on a domestic, industrial and ceremonial level is also represented at Altira Park by field systems.

5.6 Iron Age

The Iron Age is, by definition a period of established rural farming communities with extensive field systems and large 'urban' centres (the Iron Age 'Tribal capital' or *civitas* of the *Cantiaci*, the tribe occupying the area that is now Kent, was Canterbury). The Kent HER records several small finds in the vicinity of the development site including coins. Again recent archaeological investigations at Altira Business Park have revealed Iron Age round houses, rubbish pits, middens, and extensive field systems.

5.7 Romano-British

The Romano-British period is the term given to the Romanised culture of Britain under the rule of the Roman Empire, following the Claudian invasion in AD 43, Britain then formed part of the Roman Empire for nearly 400 years.

The predominant feature of the Roman infrastructure within Kent is arguably the extensive network of Roman roads connecting administrative centres: the towns to military posts and rural settlements (villas, farmsteads and temples) increasing the flow of trade, goods, communications and troops. Canterbury or *Durovernum Cantiacorum* was a major town of the Roman province of Britannia and the regional capital.

The assessment area includes several records from this period. A Romano-British cremation was found in the early 19th century some 115m west of the development site (Kent HER: TR 16 NE 15). Some 850m east of the development site a complex site of Roman ditches and post holes superimposed upon an Early Iron Age enclosure has been recently recorded (Kent HER: TR26 NW 220) whilst on the Altira Park recent archaeological investigations have recovered three Romano-British cremations, field systems and enclosures.

5.8 Anglo-Saxon

The Anglo-Saxon period is represented by a clawed beaker found in 1904 at Broomfield just to the north of the development site (Kent HER: TR 16 NE 10). As yet

no Anglo-Saxon features or finds have been identified on from the archaeological investigations at Altira Park.

5.9 Medieval

The medieval period is not well represented within the assessment area and the only HER data is of six Medieval seals found at Bishopstone and dating from 1066-1539AD (Kent HER: TR 26 NW 69). Medieval ditches have been traced on Altira Park from recent archaeological investigations. Field-walking the route of the Thanet Way in 1990 recovered medieval and post-medieval pot and tile.

5.10 Post-Medieval

The Post Medieval period within the assessment area is represented by a possible Beacon site at Herne, south of the development site (Kent HER: TR 16 NE20 and a Telegraph Station at Bishopstone (CAT HER 77).

5.11 Modern

Modern development within the assessment area has been limited to domestic housing, and farming – the latter being responsible for the present landscape.

5.12 Undated

There is no Kent HER undated records that fall within the assessment area.

5.13 Cartographic Sources and Map Regression

A rapid map regression exercise carried out on the proposed development area has shown that the site was undeveloped up until the early 20th century. Nine detailed maps of the area consulted dating from 1873 up to 2012 (OS historic mapping) show the area to be farmland until the building of the Altira Park.

5.14 Aerial Photographs

Research of aerial photographs held by Kent County Council and the National Monuments Record were available and studied during the writing of this report. Google Earth provided a vertical image dated to 2007 (Fig. 2).

6 ARCHAEOLOGICAL POTENTIAL

6.1 Palaeolithic, Mesolithic, Neolithic and Bronze Age

The potential for finding remains that date prior to the Iron Age within the confines of the proposed development is considered **high**.

6.2 Iron Age

The potential for finding remains dating to the Iron Age within the confines of the development site is also considered **high**.

6.3 Romano-British

The presence of Romano-British archaeology in the research area, though small but concentrated suggests that further archaeological remains associated with this period could extend into the proposed development site. The potential is therefore to be considered as **high**.

6.4 Anglo-Saxon

Anglo-Saxon archaeology within the assessment area has been represented by a single record (Kent HER Ref.: TR 16 NE 10) However, the presence of the earlier intensive farming activity suggests the potential for finding remains dating to the Anglo-Saxon period on the development site is considered as **low**.

6.5 Medieval

The presence of medieval archaeology within the assessment area is poorly represented. The potential for finding remains dating to the medieval period is therefore considered as **low**.

6.6 Post-Medieval

Evidence for post-medieval occupation in the area is abundant with a number of farms in the vicinity. The potential for finding remains dating to the post-medieval period is therefore considered as **moderate**.

7 IMPACT ASSESSMENT

7.1 Existing Impacts

The search area is for the most part, subject to farming and the potential impact on buried archaeological deposits will have been due to agricultural activities. Part of the site of the proposed development (the petrol filling station) may have been affected by the construction and landscaping of the present bridge and road works. Additionally, existing services may also have had a damaging effect. Therefore, the modern impact is considered as **high** for the filling station site and **low** for the food store and associated buildings and car parks.

7.2 Proposed Impacts

At the time of preparing this archaeological desk-top study, the extent of the proposed development consists of a food store with associated car parking, a range of business units and a petrol filling station (see Mitigation 8).

7.3 Conclusions

In keeping with the proposals set out in the National Planning Policy Framework (2012) this desk-based assessment fulfils these requirements and complies with the relevant tests for the historic environment as set out in National Policy.

8 MITIGATION

8.1 The purpose of this archaeological desk-based assessment was to provide an assessment of the contextual archaeological record, in order to determine the potential survival of archaeological deposits that maybe impacted upon during any proposed construction works.

8.2 The assessment has generally shown that the area to be developed is within an area of **high** archaeological potential.

8.3 However, the archaeology has shown to be about 50cm deep and there is a case to be made for the area planned as car parking and access road to allow the archaeology to be preserved in situ and not excavated. The archaeological horizon has been shown by evaluation to be about 50cm below ground level. Construction drawings (Figs 4-6) provided show that after topsoil strip, a capping layer 600mm thick will be overlaid on the 'natural' followed by a build up of Type 1 sub-base 150mm thick followed by three layers of binding courses and sub-base some 210mm thick (Fig. 4).

8.4 The carriageways (access roads) and footpaths have a similar construction (Fig. 5) as does the food store service yard (Fig. 6).

8.5 The proposed units 1-8 will be built with concrete pads in the range of 1.5m x 1.5m to about 2m below ground level. It is likely this type of build will impact on the buried archaeology and 'strip, map and sample' may be the preferred mitigation.

8.6 The food store may be built in a similar way but a piled foundation solution may prove to be more economic. The most effective method for mitigating the impacts of piling on significant archaeological remains is to adopt an avoidance strategy,

whereby piles are located away from archaeologically sensitive areas (*Piling and Archaeology*. An English Heritage Guidance Note 2007). Archaeological evaluation has shown that there is little, if any archaeology in the area designated for the food store.

English Heritage suggests: 'In these cases foundations can be designed so that they impact only on the less sensitive areas or on areas of existing disturbance. Where significant remains are present the possibility of providing uninterrupted spaces in the most sensitive areas should be explored. Where this is not possible or feasible then a redesign of the foundations to include raft, ground beam, frame supports, or cantilevered structures should be considered. Reducing the number of piles within groups by increasing the dimensions of the piles should be considered. Where the engineers have been closely involved with the mitigation process throughout, they will be able to design a piling layout that causes the least damage to archaeological remains and, where feasible, avoids the use of pile clusters. Even when a final pile layout is presented on schemes where a process of continuous mitigation has not been followed, it is often possible to agree alternatives with the engineers'.

8.7 For the petrol filling station site it is recommended a planning condition be drafted to enable a limited Archaeological Evaluation to be carried out on the footprint of the proposed building and underground storage tanks. This will provide an additional assessment of the nature; depth and level of survival of any archaeological deposits present within the extents of the filling station site and used further inform further mitigation if necessary.

9 OTHER CONSIDERATIONS

The Archaeological Officer has requested details of a programme and timetable for completing the post-excavation analysis and subsequent publication of the results of the excavations undertaken in 2007-2008. The excavations that are within the orbit of the present development site will be written up and integrated with the forthcoming archaeological investigations and the areas outside the present development are to itemised in a programme of works and timetable to be agreed with Kitewood Estates.

9.1 Archive

Subject to any contractual requirements on confidentiality, two copies of this desk-based assessment will be submitted to Canterbury City Council and Kent County Council (Heritage) within 6 months of completion.

9.2 Reliability/limitations of sources

The sources that were used in this assessment were, in general, of high quality. The majority of the information provided herewith has been gained from either published texts or archaeological 'grey' literature held at Kent County Council, and therefore considered as being reliable.

9.3 Copyright

SWAT Archaeology (Swale & Thames Survey Company) and the author shall retain full copyright on the commissioned report under the Copyright, Designs and Patents Act 1988. All rights are reserved, excepting that it hereby provides exclusive licence to Terrace Hill (Herne Bay) Ltd (and representatives) for the use of this document in all matters directly relating to the project.

10 ACKNOWLEDGEMENTS

The author would like to thank Terrace Hill (Herne Bay) Ltd for commissioning this report.

Paul Wilkinson PhD., MifA., FRSA.

12/03/2013

11 REFERENCES & BIBLIOGRAPHY

Allen T. *SWAT Archaeological Evaluation Report 2007*

Britchfield D. *Archaeological evaluation at Altira Business Park, Blacksole Farm, Herne Bay, Kent (Archaeological Phases III & IV) SWAT Archaeology 2008*

Helm R. *Excavations at Willow Farm, off Hooper's Lane, Broomfield, Herne Bay, Kent: Stratigraphic report*, Unpublished Canterbury Archaeological report, 2000, in the possession of the Archaeological Advisor to Canterbury City Council

Helm R. 'Willow Farm, off Hooper's Lane, Broomfield' *Canterbury's Archaeology 2000-2001*, 2003, 22-23

Helm R. 'Bogshole Lane, Broomfield' *Canterbury's Archaeology 2000-2001*, 2003, 23-24

Holmes S. C. A. *Geology of the country around Faversham* (Memoir for the 1:50,000 geological sheet 273), Geological Survey of Great Britain, 1981

Houliston M. *An archaeological evaluation: land south of the Thanet Way, Eddington, Herne Bay*, unpublished Canterbury Archaeological Trust Report, 1998, in the possession of the Archaeological Advisor to Canterbury City Council

Parfitt K. 'Herne Bay Waste Water Pipeline' in *Canterbury's Archaeology 1994/5*, 1996, 16-18

Parfitt K. and Allen, T. *An Archaeological Survey of the Thanet Way (Phases 2-4)*. Unpublished Canterbury Archaeological Trust report submitted to KCC, Dec.1990).

Parfitt K. and Hutcheson, A. *The Herne Bay Water Treatment Project: Assessment of the Archaeological Discoveries*, Unpubl. 1995 (C.A.T. Report submitted to K.C.C., March 1995)

Scott B. 'The flintwork assemblage' in Helm, R. *Archaeological excavation on land east of Bogshole Lane, Broomfield, near Herne Bat, Kent: Stratigraphic Report*, undated, unpaginated and unpublished Canterbury Archaeological Trust client report

Shand G. 'Eddington Farm, Herne Bay', *Canterbury's Archaeology 1999-2000*, 19, 2002

Shand G. *Archaeological excavations on land to the rear of the Old House, Underdown Lane, Eddington: 2003-2004 Progress Report for week ending 13th February 2004*, unpublished Canterbury Archaeological Trust, 16th February 2004, in the possession of the Archaeological Advisor to Canterbury City Council

IFA (revised 2011) STANDARD AND GUIDANCE for historic environment desk-based assessment.

National Planning Policy Statement 2010: Planning for the Historic Environment. TSO (The Stationery Office)

National Planning Policy Framework 2012.

HER data Kent County Council 2012

Appendix 1

Written Scheme of Investigation for Continued Archaeological Works at Blacksole Farm Broomfield, Herne Bay, Kent

Introduction

Swale & Thames Survey Company (SWAT) was commissioned by Kitewood Estates to carry out archaeological investigations at the above site, in accordance with requirements set out in an Archaeological Specification (Canterbury City 2007) and in discussion with the Archaeological Officer, Canterbury City Council. An archaeological evaluation, carried out by SWAT in July 2005, determined areas of archaeological significance (see below) along with archaeological sterile areas.

This document aims to set out proposals for a continued programme of archaeological mitigation for various sub-phases of the site, including a detailed plan delineating such areas.

Archaeological Evaluation

The archaeological evaluation comprised 80 trenches located within four separate fields /paddocks within the proposed development site. The evaluation indicated the presence of extensive, multi-phased remains associated with prehistoric and Roman occupation and settlement. Strong evidence suggestive of large scale prehistoric industrial activity and pottery production was evident, along with later pre-Roman/Iron Age and Roman period rural settlement, including relatively high status domestic debris and cremation deposits.

As a result, an Interim Assessment was produced highlighting areas of significant archaeological interest. The site was sub-divided into five separate arbitrary areas or zones designated by archaeological importance and using existing landmarks such as fences and hedgerows (Areas A, B, C, D1 & D2). Areas C, D1 and D2 were considered to be of high archaeological interest.

Archaeological Excavation

Following the submission of a specification, approved by Canterbury City Council, excavation commenced on Areas C and D1. This related to the area with planning consent for the construction of a DSA motorcycle test facility. Results to date have proven the presence of extensive field systems, enclosures, structures and settlement dating to the Iron Age, Roman and medieval periods. A programme of post-excavation assessment is now planned for this stage.

Further Archaeological Mitigation

As a result of the findings from the first phase of excavation, further archaeological mitigation is recommended. The table below comprises the various archaeological areas of the proposed development site, including additional enabling works, along with suggested mitigation. These recommendations were discussed and agreed during a meeting held between Canterbury City Council's Archaeological Officer, Planning Case Officer and the Client on 17th of January 2008, details of which are summarised below (see attached PDF plan for designated areas);

Archaeological Area	Summary of Archaeological Results/Impact	Suggested Archaeological Mitigation
A	Evaluation of this area exposed no archaeologically significant remains, although evidence of intermediate small scale modern activity was observed.	Strip and map land adjacent to the northern extent of the spine road in a westerly direction from Area C until significant archaeological remains are no longer present.

B	Evaluation of this area exposed no archaeologically significant remains, although evidence of intermediate small scale modern activity was observed.	
C2	Directly adjacent and to the west of recent excavations that have revealed a multi-phased archaeological settlement. This area is designated for landscaping	Strip, map and sample excavation, which leads in to Area A.
C	This area has been fully investigated and verbally signed off during site monitoring visits by the Canterbury City Council Archaeological Officer (Richard Cross).	Canterbury City Council to provide an email confirming that the site has been excavated in line with appropriate standards and that construction within this area can now commence.
C1	Area to the south of the recently constructed access road. No archaeological features were present during the evaluation. That said, the continuation of linear features within Area C suggests that field systems may continue within this area.	Strip, map and sample excavation as part of the continuation of the D2 area until significant archaeological remains are no longer present.
D1	Continuation of multi-phased settlement site revealed within Area C, along with evidence for small scale industrial activity recognised during the evaluation.	Strip, map and sample excavation of land to the immediate east of previously excavation attenuation pond within the eastern extent of the property, along with an additional strip adjacent to the southern boundary of Area C Notes: i) It is proposed that a 1m wide bund between the attenuation pond and Area D1 remain in situ in order to not only prevent site flooding, but to minimise impact of the hydrological design of the pond and to create and safer working environment. ii) An archaeological evaluation of land to the east of D1, designated Plot 11, is to be carried out in due course.
D2	Evidence for small scale industrial activity recognised during the evaluation, along with the continuation of linear features within Area C suggests that field systems may continue within this area	Strip, map and sample excavation. Note: i) Removal of spoil heap will be required prior to this area commencing
Temporary Access Road	The construction of temporary road will not involve any excavation. Type I hardcore (or similar) will be laid and compacted above the existing topsoil	No archaeological response is technically required, although it is proposed that a monitoring and recording (photographic) exercise be carried out during construction of the temporary road

Remainder of site	The remainder of the site to the east of Areas D1 and D2 has already been partially subjected to an archaeological evaluation (August 2007). It is therefore recommended that the evaluation is completed and a report submitted which will include all results along with recommendations for further archaeological mitigation, if required. Archaeological works within this area are to incorporate the Landscape Buffer Zone at the far eastern end of the site.
--------------------------	---

Summary

This document has summarised areas of archaeological potential within the proposed development area at Blacksole Farm. Suggested mitigation has been provided, based on agreements made in principle with the Archaeological Officer and Planning Officer at Canterbury City Council during meeting held in January 2008. This document will be subject to confirmation by the Archaeological Officer at Canterbury City Council. All confirmation will be provided in writing.

Dr Paul Wilkinson SWAT Archaeology
22 January 2008



Plate.1 Part of the development site under archaeological investigation in 2008. See "Archaeological evaluation Report Phases III & IV (photo taken facing east)



Plate 2. Site of the proposed service station (facing west)

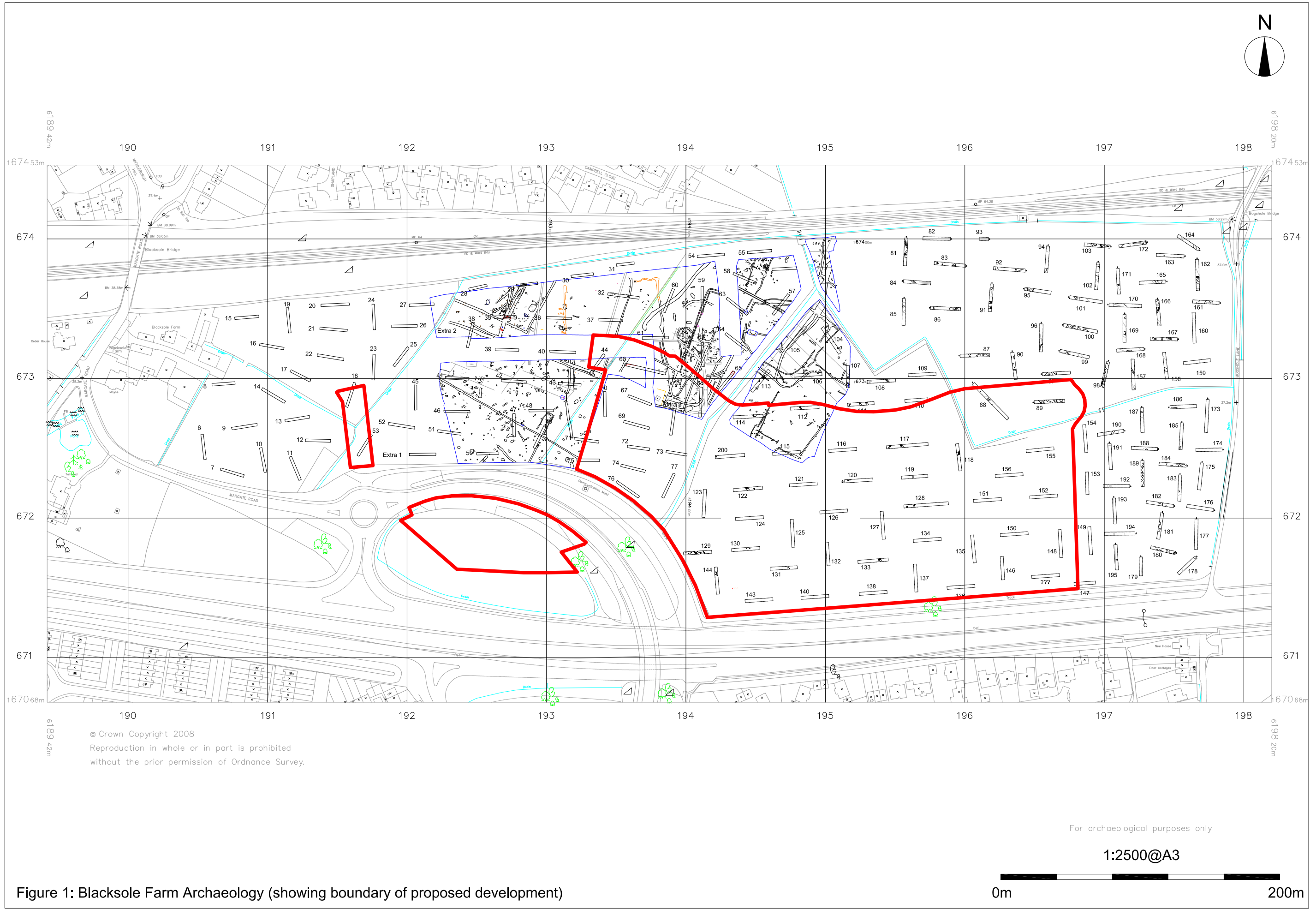

Figure 1: Blacksole Farm Archaeology (showing boundary of proposed development)



Figure 2: Blacksole Farm Archaeology (showing boundary of proposed development and aerial image)



Figure 3: Blacksole Farm Archaeology (showing boundary of proposed development and aerial image)

CDM Regulations 2007 : Reg. 11

None of the following is deemed to relieve any contractor of his obligation under all applicable health and safety legislation.

In preparing the design shown on this and related drawings Upton McGougan has considered and, where reasonably practicable, avoided foreseeable risks.

Significant risks, which remain, are listed below and identified thus  and should be given particular attention by all those carrying out works of construction or of future maintenance.

1. no significant risks
- 2.
- 3.

- NOTES**
1. THIS DRAWING IS TO BE READ IN CONJUNCTION WITH ALL RELEVANT ARCHITECTS, ENGINEERS, SERVICES AND SPECIALIST DRAWINGS AND SPECIFICATION.
 2. ANY DISCREPANCIES IN DIMENSIONS OR DETAILS ON OR BETWEEN THESE DRAWINGS SHOULD BE DRAWN TO THE ATTENTION OF THE ARCHITECT AND/OR THE ENGINEER IN WRITING FOR CLARIFICATION.
 3. ALL DIMENSIONS ARE IN MILLIMETRES. ALL LEVELS ARE IN METRES. DO NOT SCALE THIS DRAWING, PRINT, PLOT OR DISK.
 4. THIS DRAWING IS THE COPYRIGHT OF THE CONSULTANTS AND MUST NOT BE REPRODUCED OR USED WITHOUT THEIR PERMISSION.

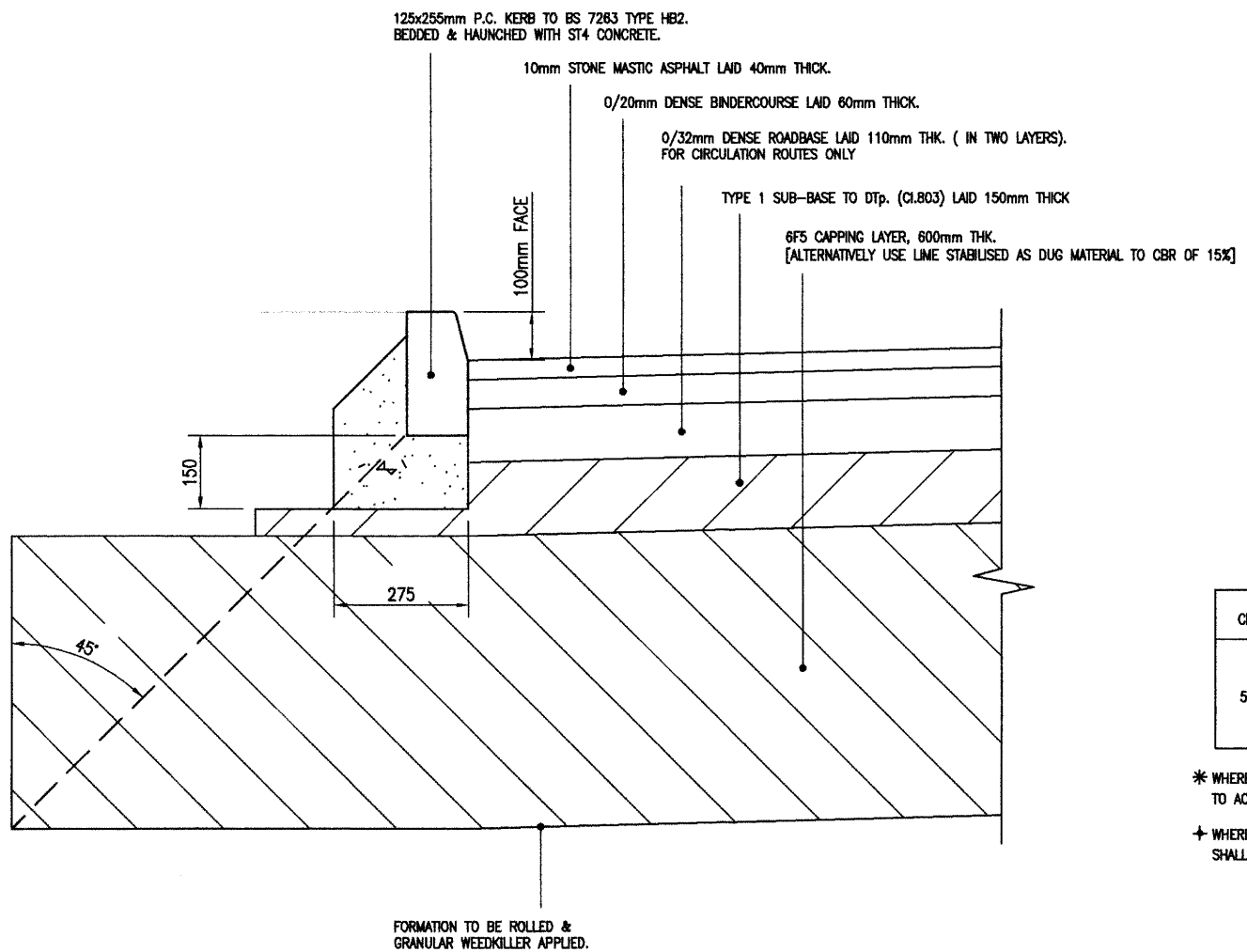

CBR %	SUB-BASE	CAPPING
>5	300 *	-
5-2	150	350
<2	150	600 †

* WHERE SUB-GRADE IS FROST SUSCEPTIBLE TO ACHIEVE 450mm CONSTRUCTION.

† WHERE CBR IS LESS THAN 2% THE FORMATION SHALL BE LINED WITH 'TERRAM 1000' OR SIMILAR.

Figure 4.

Project
 ALTRA BUSINESS PARK
 TERRACE HILL DEVELOPMENT
 HERNE BAY, KENT

Drawing Title
 FOOD STORE ACCESS ROAD / CAR PARK
 TYPICAL CONSTRUCTION DETAILS

 Upton McGougan Ltd
 Partnership House
 Moorside Road, Winchester
 Hampshire, SO23 7RX
 Tel: 01962 834400
 Fax: 01962 834411
 website: www.uptonmcgougan.com
 email: win@uptonmcgougan.com



Revision	Drawn	Date	Checked	Date	Rev
P1	MM	20 FEB 2013	MD	FEB 2013	P1

Scale
1:10

Drawing Number
221.0010-2101

(AT A3 SIZE)

14/07/2011

CDM Regulations 2007 : Reg. 11

None of the following is deemed to relieve any contractor of his obligations under all applicable health and safety legislation.

In preparing the design shown on this and related drawings Upton McGougan has considered and, where reasonably practicable, avoided foreseeable risks. Significant risks, which remain, are listed below and identified there and should be given particular attention by all those carrying out work of construction or of future maintenance.

1. no significant risks
- 2.
- 3.

NOTES

1. THIS DRAWING IS TO BE READ IN CONJUNCTION WITH ALL RELEVANT ARCHITECTS, ENGINEERS, SERVICES AND SPECIALIST DRAWINGS AND SPECIFICATION.
2. ANY DISCREPANCIES IN DIMENSIONS OR DETAILS ON OR BETWEEN THESE DRAWINGS SHOULD BE DRAWN TO THE ATTENTION OF THE ARCHITECT AND/OR THE ENGINEER IN WRITING FOR CLARIFICATION.
3. ALL DIMENSIONS ARE IN MILLIMETRES. ALL LEVELS ARE IN METRES. DO NOT SCALE THIS DRAWING, PRINT, PLOT OR DISK.
4. THIS DRAWING IS THE COPYRIGHT OF THE CONSULTANTS AND MUST NOT BE REPRODUCED OR USED WITHOUT THEIR PERMISSION.

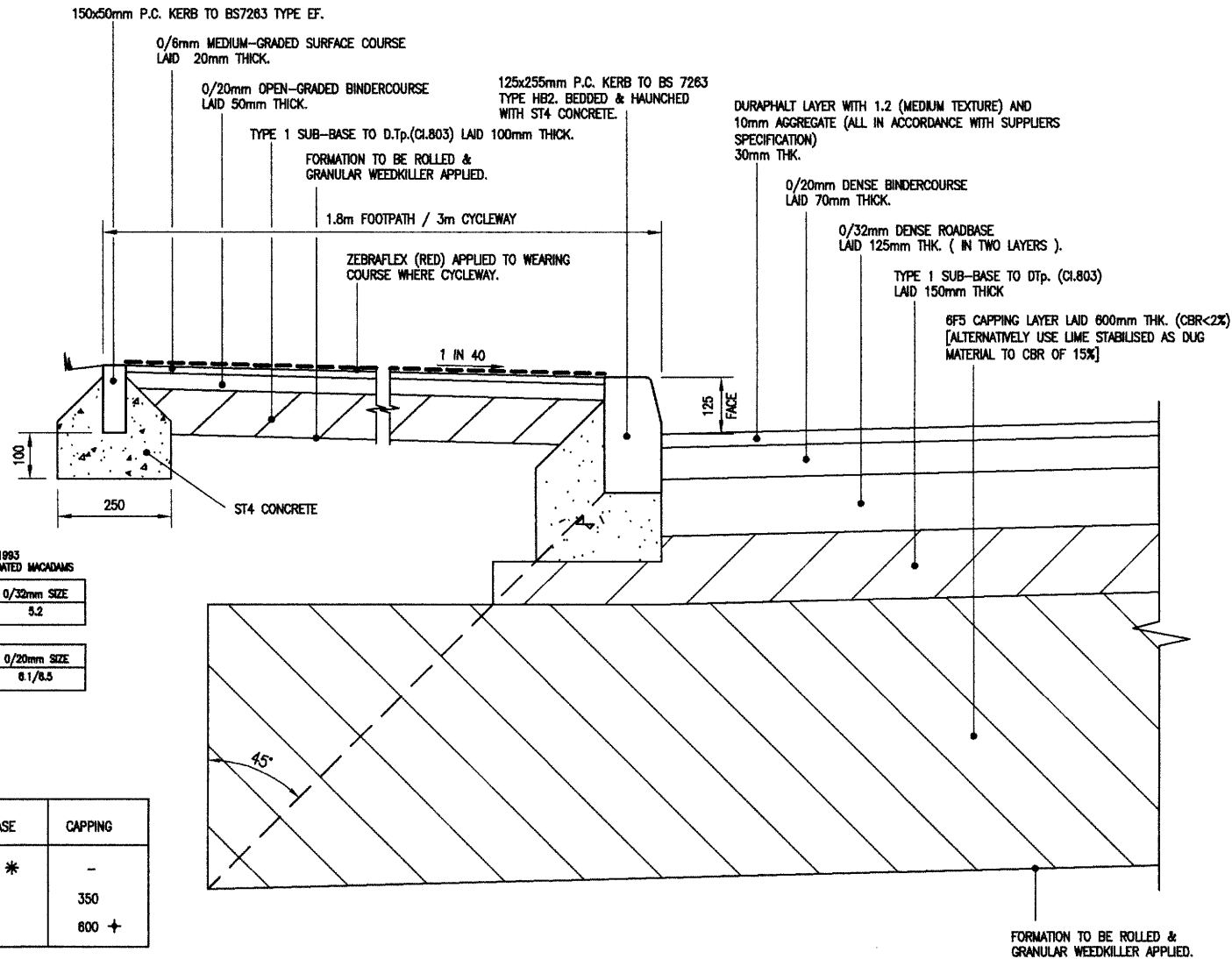

BS 4987 : PART 1 : 1993
REQUIREMENTS FOR COATED MACADAMS

DENSE BASE	0/32mm SIZE
CLAUSE No.	9.2

DENSE BINDER COURSE	0/20mm SIZE
CLAUSE No.	8.1/8.5

CBR %	SUB-BASE	CAPPING
>5	300 *	-
5-2	150	350
2	150	600 †

* WHERE SUB-GRADE IS FROST SUSCEPTIBLE TO ACHIEVE 450mm CONSTRUCTION.

† WHERE CBR IS LESS THAN 2% THE FORMATION SHALL BE LINED WITH 'TERRAM 1000' OR SIMILAR.

Project
ALTRA BUSINESS PARK
TERRACE HILL DEVELOPMENT
HERNE BAY, KENT

Drawing Title
CARRIAGEWAY AND FOOTWAY
TYPICAL CONSTRUCTION DETAILS



Upton McGougan Ltd
Partnership House
Moorside Road, Winchester
Hampshire, SO23 7RX
Tel: 01962 834400
Fax: 01962 834411



websites: www.uptonmcgougan.com
email: win@uptonmcgougan.com



Figure 5

PRELIMINARY		P1 MM MD 2102	
Revision	Date	Checked	By App. Date
MM	20 FEB 2013	MD	FEB 2013
Scale 1:10			
Drawing Number 221.0010-2102		Rev P1	

6

DO NOT SCALE THIS DRAWING, PRINT, PLOT OR DISK.

CDM Regulations 2007 : Reg. 11

None of the following is deemed to relieve any contractor of his obligation under all applicable health and safety legislation.

In preparing the design shown on this and related drawings Upton McGoogan has considered and, where reasonably practicable, avoided foreseeable risks. Significant risks, which remain, are listed below and identified from and should be given particular attention by all those carrying out works of construction or of future maintenance.

1. no significant risks
- 2.
- 3.

NOTES

1. THIS DRAWING IS TO BE READ IN CONJUNCTION WITH ALL RELEVANT ARCHITECTS, ENGINEERS, SERVICES AND SPECIALIST DRAWINGS AND SPECIFICATION.
2. ANY DISCREPANCIES IN DIMENSIONS OR DETAILS ON OR BETWEEN THESE DRAWINGS SHOULD BE DRAWN TO THE ATTENTION OF THE ARCHITECT AND/OR THE ENGINEER IN WRITING FOR CLARIFICATION.
3. ALL DIMENSIONS ARE IN MILLIMETRES. ALL LEVELS ARE IN METRES. DO NOT SCALE THIS DRAWING, PRINT, PLOT OR DISK.
4. THIS DRAWING IS THE COPYRIGHT OF THE CONSULTANTS AND MUST NOT BE REPRODUCED OR USED WITHOUT THEIR PERMISSION.

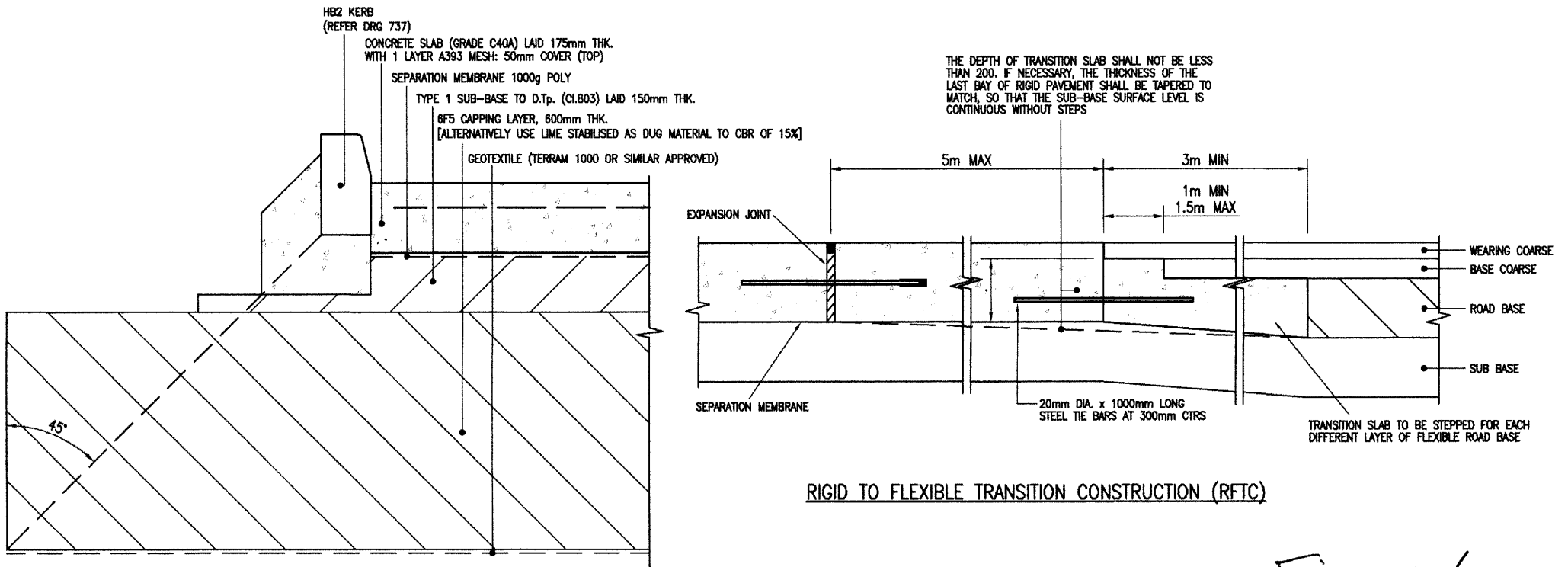
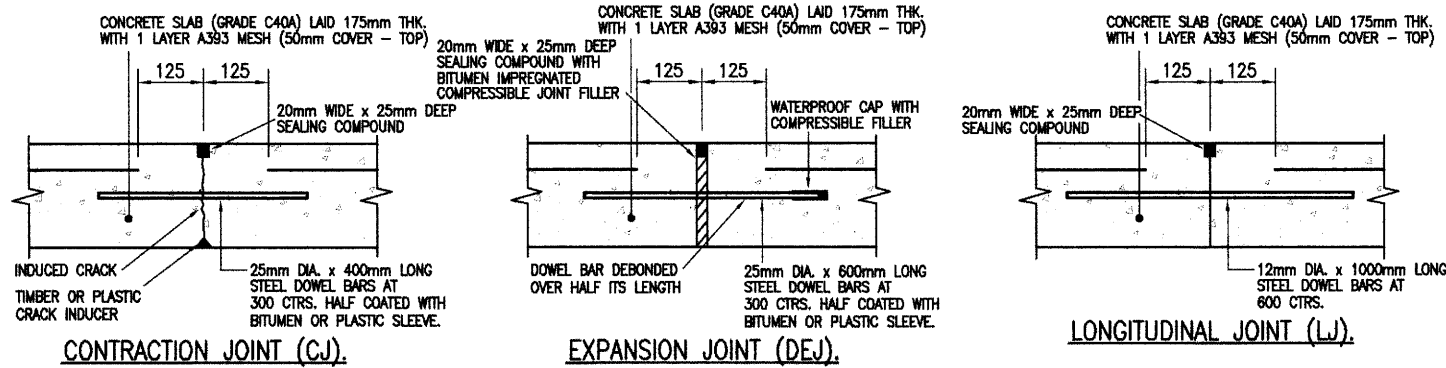

Figure 6

Project
**ALTRA BUSINESS PARK
 TERRACE HILL DEVELOPMENT
 HERNE BAY, KENT**

Drawing Title
**FOOD STORE SERVICE YARD
 TYPICAL CONSTRUCTION DETAILS**

Upton McGoogan Ltd
 Partnership House
 Moorside Road, Winchester
 Hampshire, SO23 7RX
 Tel: 01962 834400
 Fax: 01962 834411
 website: www.uptonmcgoogan.com
 email: win@uptonmcgoogan.com



Revision	Date	Checked	Date
PRELIMINARY		P1	MM MD 21/03
MM	20 FEB 2013	MD	FEB 2013

Scale
 1:10
 Drawing Number
221.0010-2100
 Rev
 P1